

ENVIRONMENTAL AND ENERGY ASSESSMENT OF NEW VEHICLE TECHNOLOGIES IN THE GREATER ATHENS AREA

**C. XIOURAS¹, A. ANGELIS-DIMAKIS¹, G. ARAMPATZIS¹, and
D. ASSIMACOPOULOS¹**

¹ Environmental and Energy Management Research Unit, School of Chemical Engineering, National Technical University of Athens, 9 Heroon Polytechniou str., Zografou Campus, Athens, GR-15780, Greece.
e-mail: assim@chemeng.ntua.gr

EXTENDED ABSTRACT

The transport sector in Greece has the largest share in the final energy consumption and thus a great potential for energy savings. The resulting emissions are also one of the main sources of atmospheric pollution. This situation is worse in the prefecture of Attica, where almost half of the country's private cars circulate in an area equal to the 3% of the total country area. Gasoline and diesel fuels are used almost exclusively in present internal combustion engines. The low efficiency of these engines, the environmental problem caused by cars and the limitation of fossil fuels are demanding new engine technologies and new fuels.

This paper examines energy saving and environmental impacts reduction from the penetration of eco-friendly technology passenger cars in the Greater Athens Area. Three vehicle technologies are considered: (i) conventional hybrid electric vehicles, (ii) battery electric vehicles and (iii) fuel cell electric vehicles.

The displacement of gasoline consumption largely depends on the level of penetration of new technologies in the vehicle fleet. The hybrid and battery electric vehicles have already been introduced in the market but their share is still low. On the other hand, fuel cell vehicles still need more improvement before their commercialization. For these reasons, two alternative scenarios are formulated. The first one involves the substitution of all the passenger cars that were registered during the last year (2010) with hybrid and battery electric vehicles that already exist in the Greek market. The second scenario examines the penetration of fuel cell electric vehicles. For the purpose of this analysis, a number of fuel cell vehicles are designed that satisfy common performance requirements, similar to the existing cars.

A parametric vehicle energy consumption model has been adapted for the analysis. The share of registered passenger car technologies and the annual vehicle kilometres for the study area are taken from literature data sources. Two different driving cycles, the New European Driving Cycle and the Athens Driving Cycle are used and the results are compared. The sizing of fuel cell vehicle components is achieved using a vehicle design model, on the basis of input performance constraints.

Both scenarios are evaluated on the basis of their expected energy savings and greenhouse gas emissions reduction. A 5% to 7% reduction of the CO₂ emissions is expected if these measures are applied in a five year period.

Keywords: Transport Sector, Energy Savings, GHG Emissions, Greater Athens Area.

1. INTRODUCTION

Intense urbanization and economic growth of the past decades has excessively increased the demand for private transport vehicles and longer road networks. This trend has resulted in a serious increase of the final energy consumption and transport sector has become one of the main sources of atmospheric pollution. Road transportation is responsible for almost all CO emissions, for about 75% of HC emissions and VOCs, and for about 65% of the NO_x emissions in urban areas (Tzirakis et al., 2006).

The situation is even worse in Greece, as the increase refers mostly to internal combustion vehicles using gasoline or diesel. In 2008 vehicle fleet was doubled comparing to 1990, with the share of medium and heavy load vehicles having significantly increased (from 15% in 1990 to 35% in 2008). Subsequently, CO₂ emissions from 1990 to 2008 show a 68% increase and N₂O emissions an 85% increase. At the same period energy consumption of the transport sector has indicated a 71% increase. The problem is more acute in the prefecture of Attica, where almost half of the country's private cars circulate in an area equal to the 3% of the total country area (MINENV, 2009).

In the recent years, the automotive industry focuses on eco-friendly technology, the realization of zero pollution and the development of green vehicles by increasing system energy efficiency and reducing exhaust emissions (Xiaolan et al, 2011). As a result new advanced vehicle technologies have been developed and implemented, using alternative fuels such as hydrogen, biofuels and/or electricity, which ultimately would reduce the emissions and energy consumption.

The objective of the present paper is the assessment of the penetration of new technology passenger cars in the transport sector of Greater Athens Area, towards energy savings and reduction of the greenhouse gas (GHG) emissions. Three vehicle technologies are examined:

- Hybrid electric vehicles (HEVs), that improve fuel economy, offer low emissions and take the advantage of existing fuel infrastructure.
- Battery electric vehicles (BEVs), which are more energy efficient, have zero tail pipe emissions but have higher cost, limited travel range and lack of recharging infrastructure.
- Fuel cell electric vehicles (FCEVs), that when combined with the right source of energy (hydrogen), have the highest potential efficiencies and lowest emissions of any vehicular power source.

The HEVs and BEVs have already been introduced in the market but their share in the total vehicle fleet is still low. On the other hand, it is currently believed that FCEVs need at least five more years of testing and improvement before large scale commercialization can begin. Economic and environmental analyses show that FCEVs will likely be both economically competitive and environmentally friendly and the transition of the transportation sector to the use of FCVs will represent one of the biggest steps toward the hydrogen economy (Veziroglu and Macario 2011).

2. METHODOLOGY DESCRIPTION

The energy and environmental assessment of vehicles is based on two models. First, an *energy consumption model* is used to calculate the vehicle's fuel and/or electricity consumption over various driving cycles. Second, a *vehicle design model* is used to estimate component sizes necessary to satisfy specific performance constraints. The vehicle design model couples the energy consumption model, to be able to capture mass compounding in the sizing of components.

2.1 Energy Consumption Model

The energy consumption model is based on the Parametric Analytical Model of Vehicle Energy Consumption (PAMVEC) (Simpson, 2005), that predicts vehicle energy consumption on the basis of a parametric driving cycle description, total vehicle mass, other attributes of the vehicle platform (such as drag coefficients and accessory loads) and the powertrain component efficiencies.

A diagram of the generic powertrain architecture is shown in Figure 1. HEVs, FCEVs and the conventional internal combustion vehicles (ICVs), incorporate a fuel engine that provides the energy required to complete a driving pattern. The engine is capable of handling mono-directional power flows only. HEVs incorporate an electric motor that provides peak power capability, in addition to the engine. On the other hand, BEVs rely solely on the electric motor. The motor/battery component also acts as an energy buffer mechanism that can be used as a generator to charge the battery by either the regenerative braking or absorbing the excess power from the engine when its output is greater than that required to drive the wheels.

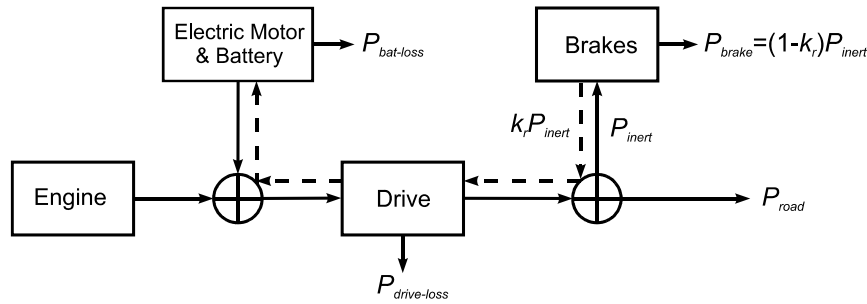

Figure 1: Generic powertrain architecture of a vehicle.

The average power input requirement that must be provided by the engine and/or the electric motor (P_{tot}) is calculated as follows:

$$P_{tot} = P_{road} + P_{brake} + P_{drive-loss} + P_{bat-loss} + P_{acc} \quad (1)$$

where P_{road} is the power required to overcome drag and friction forces, P_{brake} is the braking losses, $P_{drive-loss}$ is the drivetrain losses, $P_{bat-loss}$ is the losses during the regenerative action of the electric motor and P_{acc} is the power supplied to the accessories of the vehicle. The expressions for the first four terms in the above equation are:

$$P_{road} = \frac{1}{2} \rho C_{DA} V_{mc}^3 + C_{RR} m_{tot} g v_{avg} \quad (2)$$

$$P_{brake} = (1 - k_r) P_{inert} \quad (3)$$

$$P_{drive-loss} = \frac{1 - \eta_{drive}}{\eta_{drive}} (P_{road} + P_{inert}) + (1 - \eta_{drive}) k_r P_{inert} \quad (4)$$

$$P_{bat-loss} = \frac{(1 - \eta_{bat})(1 + k_r)}{2} P_{inert} \quad (5)$$

where C_{DA} the drag area (the product of aerodynamic drag coefficient and the frontal area), C_{RR} the rolling resistance coefficient, m_{tot} the total vehicle mass, η_{bat} and η_{drive} the efficiencies of the battery and the drivetrain and k_r the regenerative braking fraction. The term $P_{inert} = k_m m_{tot} a_{ch} v_{avg}$ represents the average rate of kinetic energy storage in the vehicle inertia, where k_m is a factor to account for the rotational inertia of the powertrain. ICVs and FCEVs, that lack a regenerative buffer mechanism, have $k_r = 0$ and $P_{bat-loss} = 0$.

A novel feature of the above equations is the use of only three parameters to fully characterise the driving pattern during the total trip time T :

$$v_{avg} = \frac{1}{T} \int_0^T v dT \quad \text{Average Velocity} \quad (6)$$

$$v_{rmc} = \sqrt[3]{\frac{1}{T} \int_0^T v^3 dT} \quad \text{Root-Mean-Cube Velocity} \quad (7)$$

$$\alpha_{ch} = \frac{1}{2} \frac{\sum (v_{final}^2 - v_{initial}^2)}{v_{avg} T} \quad \text{Characteristic Acceleration} \quad (8)$$

2.2 Vehicle Design Model

The vehicle design model estimates the powertrain component sizes on the basis of four input performance constraints: (i) top speed, (ii) gradability, (iii) standing acceleration and (iv) driving range. It is based on an iterative procedure (Figure 2) for estimating the total vehicle mass, which is a key contributor to overall energy consumption.

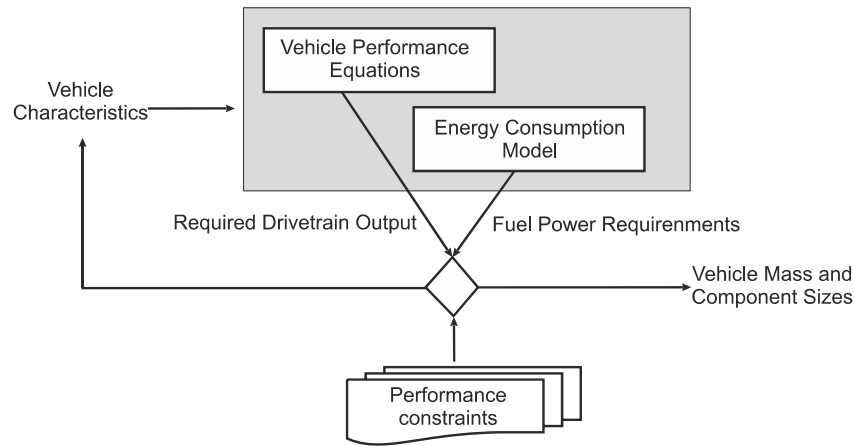

Figure 2: The vehicle design model.

The expression for the total mass of a vehicle is given by:

$$m_{tot} = m_{glider} + m_{cargo} + k_{struct} m_{powertrain} \quad (9)$$

The parameters m_{glider} and m_{cargo} are considered constant. Since different powertrain architectures utilise different components, the expressions for $m_{powertrain}$ are different. The parameter k_{struct} accounts for the mass of additional structural support that may be required to support the powertrain.

The crucial element in the vehicle design model is to relate the total vehicle mass to the performance criteria. This relation, for the first three constraints, is given by the following *vehicle performance equations*, specifying the required drivetrain output:

$$P_{drive-out} = \frac{1}{2} \rho C_{DA} v_{ts}^3 + C_{RR} m_{total} g v_{ts} \quad \text{Top speed} \quad (10)$$

$$P_{drive-out} = \frac{1}{2} \rho C_{DA} v_{gr}^3 + C_{RR} m_{tot} g v_{gr} + m_{tot} g Z_{gr} v_{gr} \quad \text{Gradability} \quad (11)$$

$$P_{drive-out} = \frac{N^2 + 1}{N^2} \frac{k_m m_{tot} v_{acc}^2}{2t_{acc}} + \frac{1}{2} (\rho C_{DA} v_{acc}^3 + C_{RR} m_{tot} g v_{acc}) \quad \text{Acceleration} \quad (12)$$

where v_{ts} is the required continuous top speed, Z_{gr} the required gradability at the speed of V_{gr} , t_{acc} the time taken to accelerate to the terminal speed v_{acc} , and N is the drivetrain overspeed ratio. More details on the relation between $P_{drive-out}$ and $m_{powertrain}$ for different vehicle technologies can be found in Simpson, 2005.

The driving range constraint specifies the size of the vehicle's energy storage system (engine and/or battery). For vehicles with a fuel tank, the size of the energy storage system (in Wh) is related to the average flow of fuel (calculated by the energy consumption model) as follows:

$$E_{fuel} = range \frac{P_{tol} / \eta_{engine}}{V_{avg}} \quad (13)$$

where $range$ is the driving range requirement and η_{engine} the efficiency of the engine

3. CASE STUDY - GREATER ATHENS AREA

3.1 Driving Cycle

The calculation of energy consumption from passenger cars is usually based on the New European Driving Cycle (NEDC) (Figure 3.a). This cycle is assembled from major European capitals traffic data (Paris and Rome) and is applied in laboratory test approvals in the EU. Traffic data from Athens was not included in the development of NEDC. All road traffic in Athens encounters significant delays and small speeds, which lead to long travel times. Traffic congestion and delays are not helped by the fact that a significant percentage of roads are either narrow or at large grade. It has been estimated that the overall daily average corresponding traffic speed throughout the main urban areas is about 23 km/h, while the average speed in the remote suburbs is 35 km/h and in the semi-rural areas 52 km/h. Speeds during the peak hours and on the central region are much lower, though in many cases less than 10 km/h (Arampatzis et al., 2004).

Recent studies have shown that the European driving cycle is not suitable for the emission and fuel consumption estimation for passenger cars driven in Attica Basin. That is why the Athens Driving Cycle (ADC) (Figure 3.b), has been developed, based on actual driving data that are collected in the whole area of the Attica basin seven days a week from 6:00 until 24:00. Fuel consumption showed an increase for ADC compared to NEDC in percentages that vary from 56% to about 79% (Tzirakis et al., 2006).

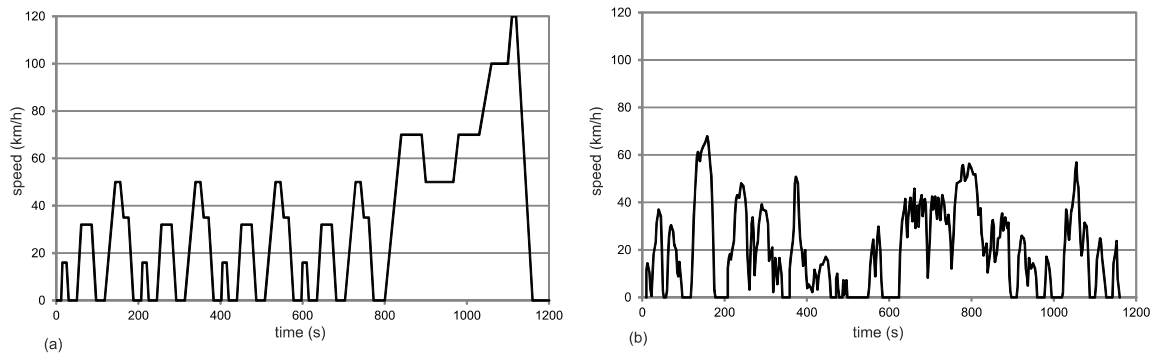

Figure 3: (a) New European and (b) Athens driving cycles.

Both driving cycles are used in this study and the results are compared. Their parameters, as used in energy consumption model, are presented in Table 1.

Table 1: Characteristic parameters of the driving cycles

Category	NEDC	ADC
Average Velocity	33.6 km h ⁻¹	19.8 km h ⁻¹
Root-Mean-Cube Velocity	53.5 km h ⁻¹	31.2 km h ⁻¹
Characteristic Acceleration	0.11 m sec ⁻²	0.25 m sec ⁻²
Total Trip Time	1180 sec	1160 sec

3.2 Passenger cars registered in 2010

Passenger cars are classified into categories according to the European Classification, based on their length and on their engine characteristics. For the purposes of this study, only five of the categories considered (A-mini cars, B-small cars, C-medium cars, D-large cars and SUV) which represent 90% of the total market share. It is also assumed that all vehicles travel in average a distance of 10,000 km annually in urban areas (I. Ziomas, personal communication, April 13, 2010).

Table 2 exhibits the number of new cars that were registered during the last year (2010), for each one of those five categories and the respective market share as well as the characteristics of a typical vehicle for each category (Ecomodder, 2011, Carfolio, 2011) and its energy consumption (in liters of gasoline per 100 vehicle kilometres), as it was calculated by the model. The mean fuel consumption over all registered cars is 7.6 and 10 L/100 km for NEDC and ADC, respectively.

Table 2: Vehicles registered in 2010 and their characteristics (AMVIR, 2010)

Category	Vehicles Registered in 2010	Market Share	Mass (kg)	Drag Area (m ²)	Engine Efficiency	Fuel Consumption (L _{gas-eq} /100km)	
						NEDC	ADC
A	12436	16.5%	860	0.7	0.22	6.9	8.4
B	25129	33.4%	1040	0.57	0.25	6.2	8.2
C	20098	26.7%	1220	0.58	0.2	8.5	11.5
D	5737	7.6%	1500	0.57	0.18	10.6	14.8
SUV	4330	5.7%	1340	0.94	0.22	9.4	11.6
Mean Fuel Consumption						7.6	10

3.3 Penetration of parallel hybrid electric and battery electric vehicles

The first scenario to be examined involves the substitution of all the passenger cars that were registered in 2010 with HEVs and BEVs that already exist in the market. Table 3 presents the characteristics of five indicative new technology passenger cars, which are sold in the Greek market. The same Table presents the fuel consumption as calculated by the energy consumption model. The consumption is expressed in liters of gasoline equivalent (L_{gas-eq}) per 100 vehicle kilometers. The gasoline equivalent has been proposed by the U.S. EPA to compare energy consumption of alternative fuel vehicles, with the fuel economy of conventional internal combustion vehicles (U.S. EPA, 2010).

The mean fuel consumption of all passenger cars has been reduced by 42% on NEDC and 45% on ADC (Figure 4). Subsequently, the fuel consumption in the transport sector of Athens Area has been reduced by 21,740 m³ using the NEDC or by 30,540 m³ using the ADC. Taking the gasoline emission factor equal to 2.325 tCO₂/m³, the total reduction of the emissions is 50,545 tCO₂ (NEDC) – 71000 tCO₂ (ADC). Comparing to the total CO₂ emissions from private cars circulating in the area in 2010, which is estimated to 4,706,000 tCO₂ (I. Ziomas, personal communication, April 13, 2010), the total reduction of

emissions is about 1.1%. Assuming a five year horizon for the application of this measure, the total emissions' reduction may reach from 5.5% (NEDC) to 7.5% (ADC).

Table 3: Characteristics of the existing new technology vehicles

Category	Model	Technology	Mass (kg)	Drag Area (m ²)	Engine Efficiency	Fuel Consumption (L _{gas-eq} /100km)	
						NEDC	ADC
A	Citroën C1 ev'ie	BEV	905	0.62	0.8	1.9 ¹	2.2
B	Honda Jazz	HEV	1162	0.72	0.35	4.8	5.8
C	Honda Insight	HEV	1204	0.57	0.34	4.7	6.0
D	Toyota Prius	HEV	1370	0.54	0.37	4.8	6.6
SUV	Lexus RX Hybrid	HEV	2110	0.9	0.37	7.0	9.2
Mean Fuel Consumption						4.4	5.5

3.4 Penetration of fuel cell electric vehicles

In the second scenario, the penetration of FCEVs in the Greek market is examined. For the purpose of this analysis, five FCEVs are designed on the basis of the conventional vehicles' performance indicators as shown in Table 4. The characteristics of the vehicles designed as well as the fuel consumption as calculated by the energy consumption model are presented in Table 5.

Table 4: Vehicle performance indicators

Category	Top Speed (km/hr)	Acceleration 0-100 (sec)	Gradability (km/hr)	Fuel Range (km)
A	155	14.0	100/6.5%	500
B	175	13.4	100/6.5%	677
C	178	14.2	100/6.5%	658
D	192	12.9	100/6.5%	625
SUV	175	11.8	100/6.5%	630

Table 5: Characteristics of the designed fuel cell electric vehicles

Category	Mass (kg)	Fuel Cell Power (hp)	Fuel Consumption (L _{gas-eq} /100km)	
			NEDC	ADC
A	923	68	3.1	3.8
B	1146	84	3.3	4.4
C	1261	88	3.5	4.7
D	1566	118	3.9	5.6
SUV	1686	138	4.7	6.1
Mean Fuel Consumption			3.5	4.6

The decrease in the mean fuel consumption resulting from the substitution of the vehicles registered in 2010 with FCEVs is almost 54% for both driving cycles (Figure 4). The subsequent total reduction of gasoline consumption is 27,941 m³ and the corresponding emissions' reduction is 64.963 tCO₂ when using the NEDC. The same figures increase significantly when using ADC and are equal to 36,600 m³ and 85.100 tCO₂ respectively. Considering again a five year horizon, the total reduction almost reaches 7% (NEDC) - 9% (ADC).

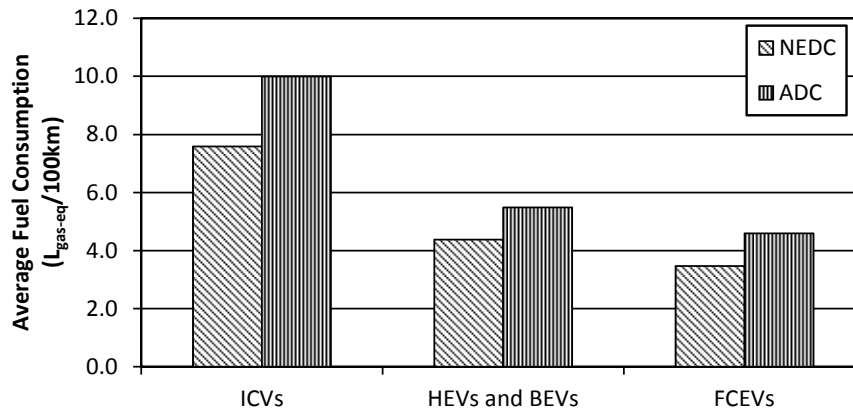

Figure 4: Average fuel consumption ($L_{\text{gas-eq}}/100\text{km}$) for each scenario.

4. CONCLUSIONS

It is obvious that the substitution of the existing private cars that were bought in 2010 for new technology vehicles can improve the reduction of energy consumption and greenhouse gas emissions in the transport sector. Results indicate a 5.5% to 9% reduction of the CO₂ emissions in the Greater Athens Area by applying this measure for 5 five years.

However, this substitution should not be examined on its own. It should be a part of wider action plan which will include incentives for withdrawing the old vehicles and subsidies for buying a new technology passenger car. This will result to the quicker penetration of new technologies in the fleet and the removal from it of the older and more polluting vehicles.

REFERENCES

1. AMVIR (2010) Association of Motor Vehicle Importers-Representatives Database URL: <http://www.seaa.gr/en/statistics/registration> (accessed 01/04/2011)
2. Arampatzis G., Kiranoudis C.T., Scaloubacas P. and Assimakopoulos D. (2004) A GIS-based decision support system for planning urban transportation policies, *Journal of Operational Research*, **152**, 465-475.
3. Carfolio (2011) Technical Specifications of Vehicles URL: <http://www.carfolio.com> (accessed 01/04/2011)
4. Ecomodder (2011) Vehicle Coefficient of Drag List URL: http://ecomodder.com/wiki/index.php/Vehicle_Coefficient_of_Drag_List (accessed 01/04/2011)
5. Ministry of Environment, Energy and Climate Change (2009) Annual Inventory Submission under the Convention and the Kyoto Protocol for Greenhouse and other Gases for the Years 1990-2007.
6. Simpson A. (2005) Parametric modelling of energy consumption in road vehicles, D.Phil Thesis, Sustainable Energy Research Group, School of Information Technology and Electrical Engineering, University of Queensland, Australia, 27-80.
7. Tzirakis E., Pitsas K., Zannikos F. and Stournas S. (2006) Vehicle emissions and driving cycles: Comparison of the Athens Driving Cycle (ADC) with ECE-15 and European Driving Cycle (EDC), *Global NEST Journal*, **8(3)**, 282-290.
8. U.S. EPA, (2010), EPA and NHTSA Propose Changes to the MotorVehicle Fuel Economy Label.
9. Veziroglu A. and Macario R. (2011) Fuel cell vehicles: State of the art with economic and environmental concerns, *International Journal of Hydrogen Energy*, **36**, 25-43.
10. Xiaolan W., Binggang C., Xueyan L., Jun X. and Xiaolong R. (2011) Component sizing optimization of plug-in electric vehicles, *Applied Energy*, **88**, 799-804.